

Practice Book
Lesson 10.4

In Exercises 8–10, find each missing length. All lengths are in centimeters.

8. $a =$
 $b =$

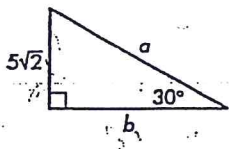

9. $c =$
 $d =$

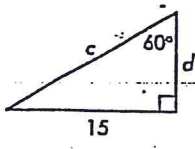

10. $e =$
 $f =$

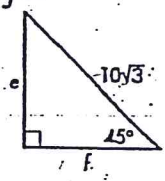

11. What are the coordinates of point A?

12. What are the coordinates of point B?

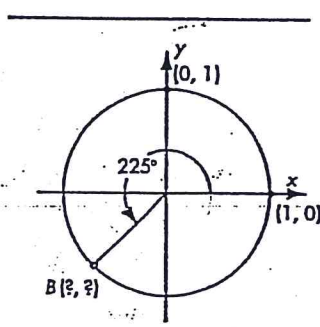
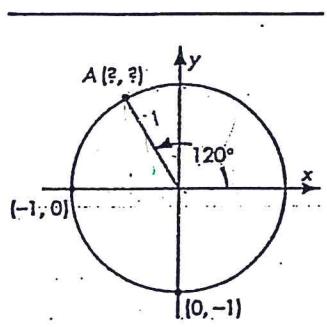

Lesson 10.5

1. $d =$ _____

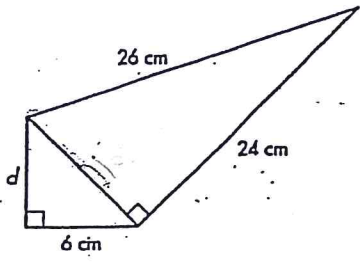

2. What are the coordinates of point C?

3. What are the coordinates of point D?

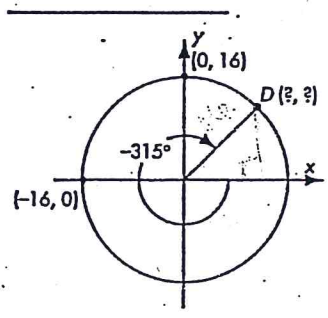
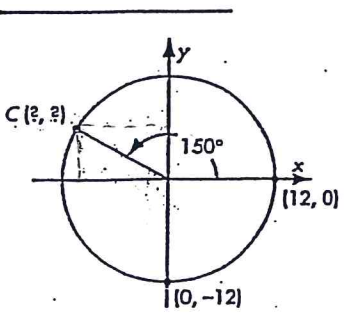

LESSON 10.7

In Exercises 4–8, use $\triangle ABC$ with vertices $A(4, 14)$, $B(10, 6)$, and $C(16, 14)$.

4. Determine whether $\triangle ABC$ is scalene, isosceles, or equilateral and find its perimeter.
5. Find the midpoints M , N , and P of \overline{AB} , \overline{AC} , and \overline{BC} , respectively.
6. Find the slopes of \overline{MN} and \overline{BC} . How do they compare?
7. Find the lengths of \overline{PN} and \overline{AB} . How do they compare?
8. Find the equation of a circle whose diameter has the endpoints $(4, -6)$ and $(-4, 0)$.

16. In the circle with diameter \overline{AB} , $AC = 8$ in and $BC = 15$ in. The perimeter of $\triangle ABC$ (to the nearest tenth of an inch is)
 - A. 35.7 in
 - B. 17.0 in
 - C. 27.8 in
 - D. 40.0 in
 - E. None of these

17. In the figure at the right $\overline{AB} \parallel \overline{DE}$, $\overline{AD} \perp \overline{AB}$, $\overline{AD} \perp \overline{DE}$, $\overline{AB} \cong \overline{CD}$ and $\overline{AC} \cong \overline{DE}$. If $AB = 5$ and $AC = 12$, then $BE =$
 - A. 18.38
 - B. $13\sqrt{2}$
 - C. 13
 - D. 17
 - E. None of these

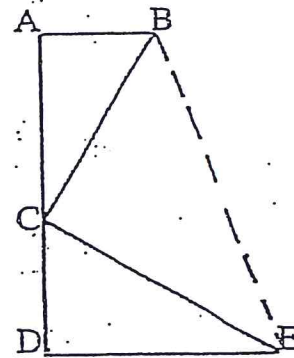

TIE-BREAKER #1

Two wires are attached to a vertical radio tower that is 60 feet high and then to the ground at points that 109 feet and 61 feet from the top of the pole. If the points where the wires are attached to the ground and the base of the pole are in a straight line and the ground around the pole is level, how far apart are the points on the ground where the wires are attached?

